

Adjustment instruction SM12

Block diagram

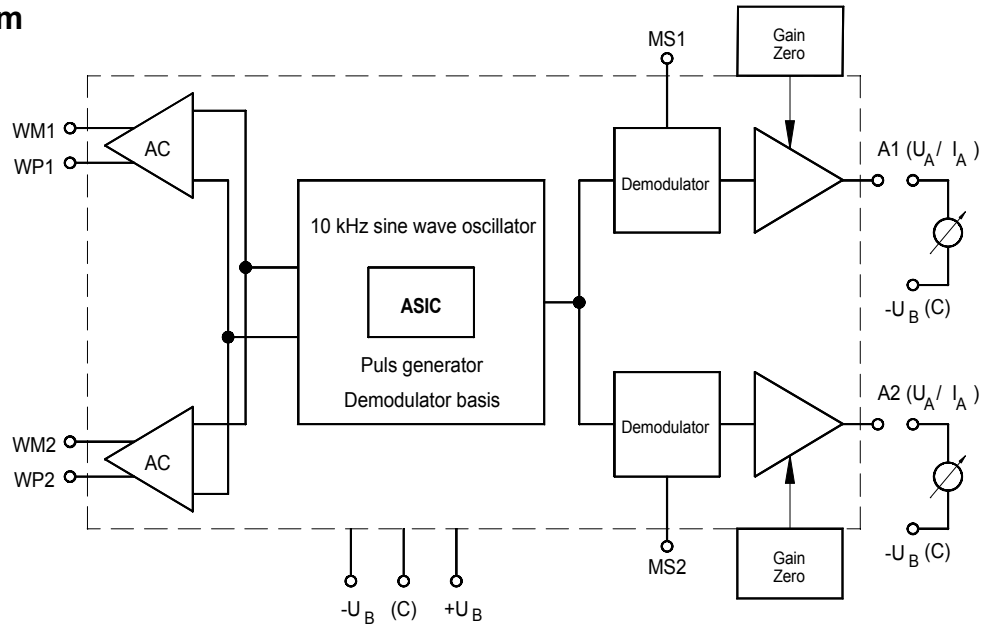

A Basic gain adjustment:

The basic gain multiplier is preset on the board by jumpers. The factory preset multiplier is 1x. To select a different gain multiplier unlock the case on both sides and pull out the board. Set the jumpers according to the following drawings:

Jumper J1: channel 1, jumper J2: channel 2

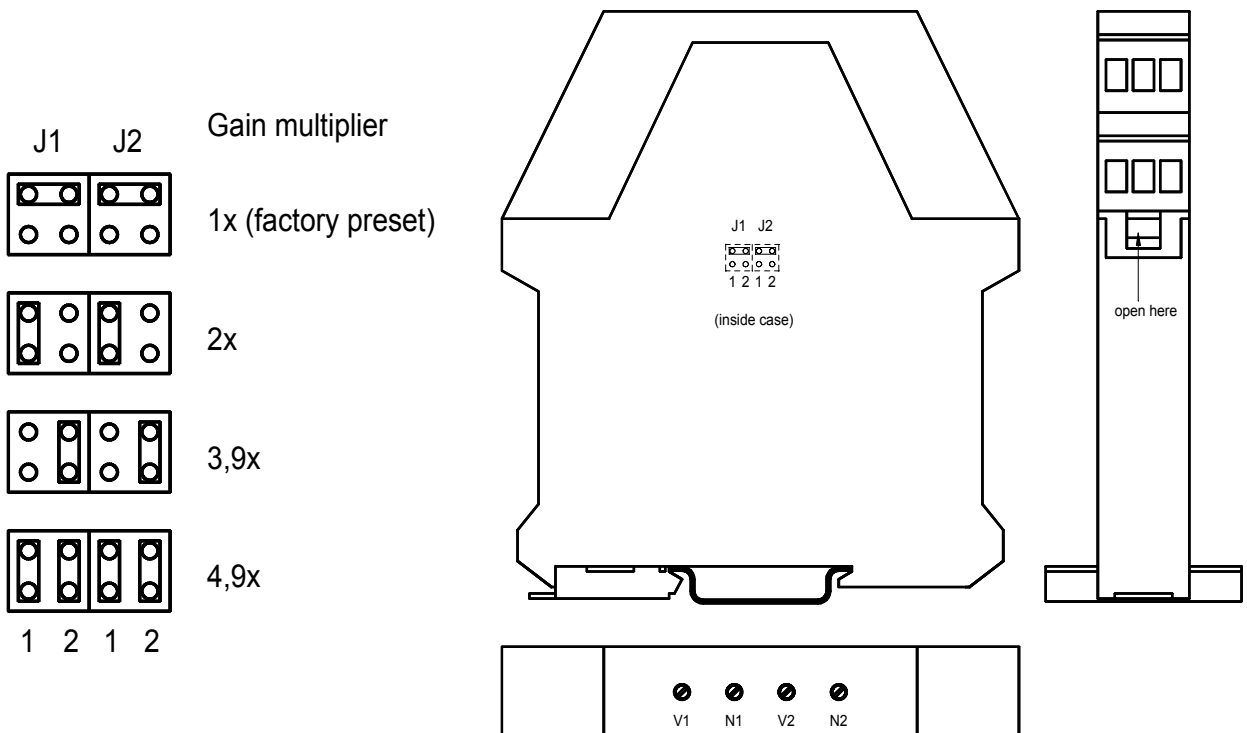

The following basic gain multipliers are recommended:

Sensor type	Stroke / angle	recommended gain multipliers
SM200/220	4 mm	3,9x or 2x
SM200/220	8 mm	2x or 1x
SM222	4 mm	3,9x or 2x
SM222	8 mm	2x or 1x
SM210/240	5 mm	2x
SM210/240	10/15 mm	1x
SM260	24/40/60/100/150/200 mm	1x
SM60	90°	2x
SM60	60°	3,9x
SM60	30°	4,9x

How to calculate the basic gain multiplier (sample):

Inductive Sensor SM210.10; Stroke 10 mm; Sensitivity 400 mV/mm (Datasheet SM21); connected to external electronic SM123.1.N:

Customer stroke 8mm:	-4 .. 0 .. +4 mm → 4 .. 12 .. 20 mA	16 mA
Demodulator voltage:	8 mm x 400 mV/mm =	3,2 V
Gain preset to:	16 mA / 3,2 V =	5 mA/V

Possible basic gain multipliers	1,9 .. 6,0 mA/V (Datasheet SM12) or 3,8 .. 12,0 mA/V	1x or 2x
---------------------------------	---	---------------------

B Connect supply voltage according to datasheet SM12

C Basic zero adjustment:

Without connecting a sensor to the electronics (WM, MS and WP without any connection) measure the output signal (= Mid-signal). The correct output signals for the electronics are:

SM121	10,0 mA	(reference -U _B)
SM123	12,0 mA	(reference -U _B)
SM125	0,0 V	(reference C)
SM127	5,0 V	(reference -U _B)

Correct different mid-signals by adjusting with the corresponding zero trimmer (N1 / N2)

D Final gain adjustment:

1. Connect sensor to WM, MS and WP. Adjust the plunger (or the shaft) mechanically in mid-position. The measured output-signal should now be the mid-signal.

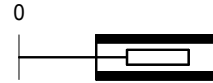

2. Now set the plunger to $\frac{1}{4}$ of the complete stroke (or angle). (sample: for ± 5 mm complete stroke set the plunger to $-2,5$ or $+2,5$ mm out of mid position).

3. Correct the output signal with the gain-trimmer (V1 / V2) to the according signal:

SM121	15,0 mA or 5,0 mA
SM123	16,0 mA or 8,0 mA
SM125	+5,0 V or -5,0 V
SM127	7,5V or 2,5V

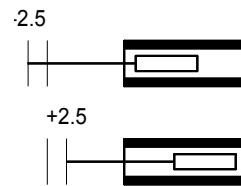

Direction (increasing or decreasing output signal by movement of the plunger in direction of the electrical connector of the sensor or moving the shaft in clockwise direction) can be switched by cross-plugging WP and WM.

4. Set the plunger to the mechanical mid-position again. The output signal should be the mid signal again. If the output signal differs, recalibrate with the according zero trimmer. If necessary repeat steps 2 to 4.

E Final zero adjustment:

The measuring range is for about $\pm 10\%$ of the stroke electronically adjustable (sample: $\pm 0,8$ mm for an 8mm range sensor)

Sample:

$-4,0 \dots 0,0 \dots +4,0$ mm \rightarrow 4 .. 12 .. 20 mA

$-3,2 \dots +0,8 \dots +4,8$ mm \rightarrow 4 .. 12 .. 20 mA

$-4,8 \dots -0,8 \dots +3,2$ mm \rightarrow 4 .. 12 .. 20 mA

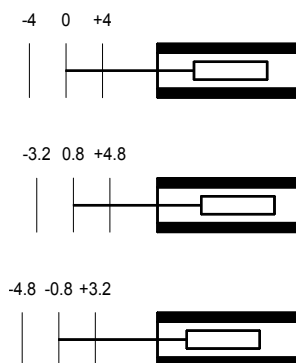

Adjustment with the zero trimmer has no effect on the gain setting.

Adjustment with the gain trimmer has small effect on the zero setting.