

## Electronic-module

### Series **SM12**

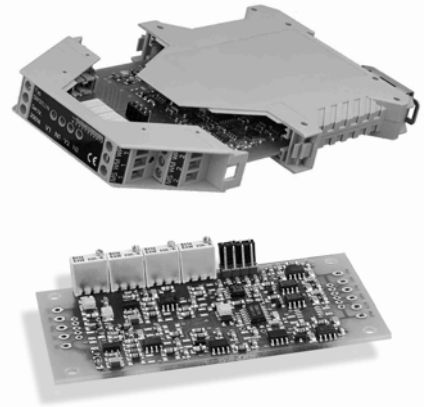

- **Electronic board with ASIC SM17**
- **To use with max. two inductive transducers**
- **Also available in snap-on DIN rail mounting cases**

### Construction and operating principle

The module series SM12 contains our ASIC SM17 for use with one or two inductive sensors. The module supplies the sensors with a stabilised carrier frequency and demodulates the measuring signal into a DC voltage or current signal proportional to the measuring stroke or angle. The gain could be preset by jumpers, the fine adjustment could be done by trimmers.

#### Standard version:

Type	output	supply voltage $U_B$ *	mid
SM121	0 .. 20 mA	21,5 .. 32V	10 mA
SM123	4 .. 20 mA	21,5 .. 32V	12 mA
SM125	$\pm 10$ V	$\pm 12$ .. $\pm 16$ V	0 V
SM127	0 .. 10 V	21,5 .. 32V	5 V

\* Pole reversal protection

#### Technical data:

Operating frequency	10 kHz
Amplitude	10 $V_{p-p}$ sine-wave
Zero-point	$\pm 10\%$ adjustable
Sensitivity	adjustable by jumper+ trimmer
Temperature drift	< 0,005% / °C
Measurement frequency	800 Hz
Temperature range	-20°C .. +85°C

#### Current output (SM121 / SM123):

Supply current $I_B$ max. 7 channels	max. 450 mA
Load resistance $R_L$	0..500 $\Omega$
Residual ripple	< 0,005 mA <sub>p-p</sub>
Dependence on $V_S$	< 0,05% at $\Delta U_B = 1$ V
Dependence on $R_L$	< 0,001% at $\Delta R_L = 100\Omega$

#### Voltage output (SM125 / SM127):

Supply current $I_B$ max. 7 channels	max. 300 mA
Permissible load $R_L$	$\geq 2$ k $\Omega$ (short-circuit proof)
Residual ripple	< 5 mV <sub>p-p</sub>
Dependence on $V_S$	< 0,05% at $\Delta U_B = 1$ V
Residual voltage SM147	max. 0,2 VDC

**The standard version is equipped with jumper and trimmer.**

#### Block diagram

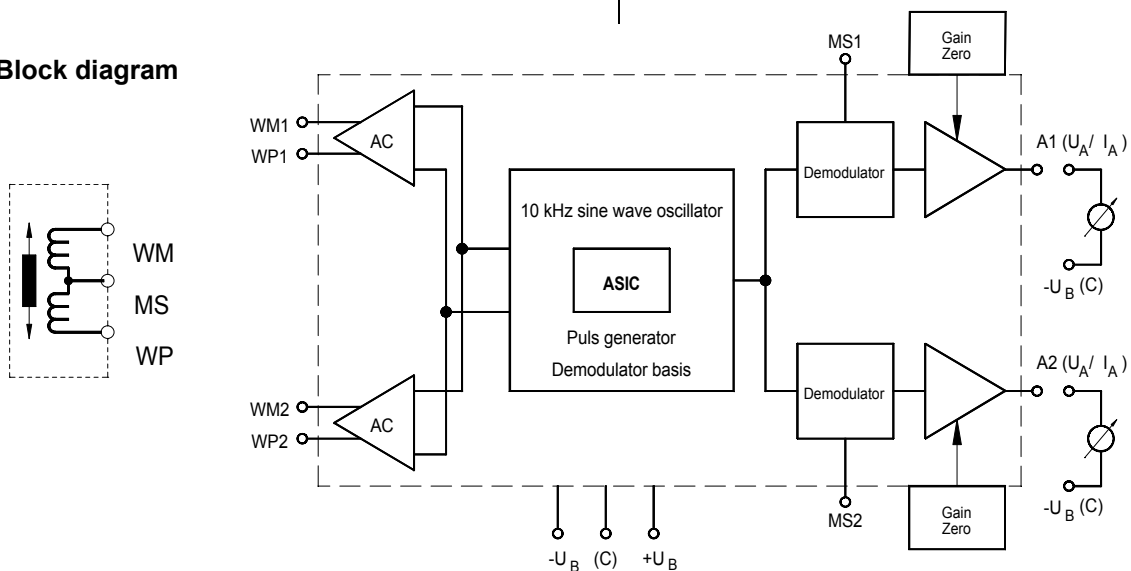

**Basic gain multiplier**

Jumper J1: channel 1

Jumper J2: channel 2

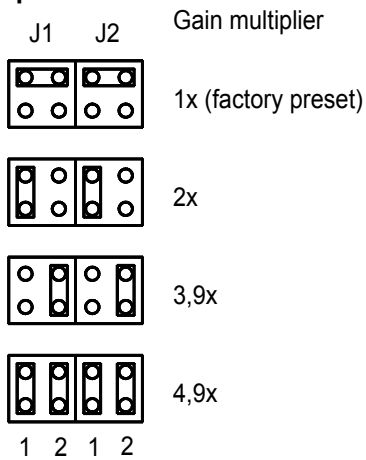
**Fine adjustment trimmer V1/V2**

Typ	gain
SM121	2,4 .. 7,6 mA/V
SM123	1,9 .. 6,0 mA/V
SM125	2,3 .. 7,5 V/V
SM127	1,2 .. 3,8 V/V

**How to calculate the basic gain multiplier**

Inductive sensor SM200.8; stroke 8mm; sensitivity 440 mV/mm; connect to an electronic module SM121; Jumper gain multiplier 1x; trimmer gain 2,4 .. 7,6 mA/V

Current output:  $0,44 \text{ V/mm} \times (2,4 \dots 7,6) \text{ mA/V} = (1,05 \dots 3,35) \text{ mA/mm}$

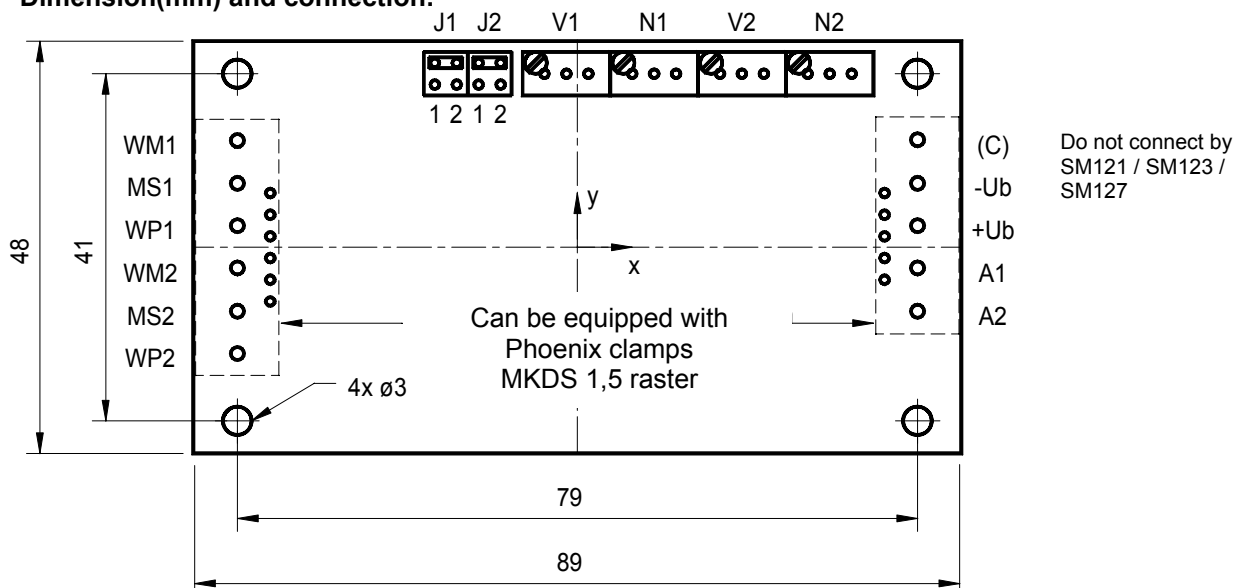
**Dimension(mm) and connection:****Coordinating of connection pins:****Raster dimension 1/10 inch**

Pin	X	Y
WM1 bis WP2	-14	2,5 / 1,5 / 0,5 / -0,5 / -1,5 / -2,5
(C) bis A2	14	2,5 / 1,5 / 0,5 / -0,5 / -1,5
V1	-1,5 / -0,5 / 0,5	8
N1	2,5 / 3,5 / 4,5	8
V2	6,5 / 7,5 / 8,5	8
N2	10,5 / 11,5 / 12,5	8
J1	-6,5 / -5,5	8,5 / 7,5
J2	-4,5 / -3,5	8,5 / 7,5

### EN-case for snap-on mounting:

Order code: SM12x.1(2)N case Phoenix ME17,5 frontside trimmers

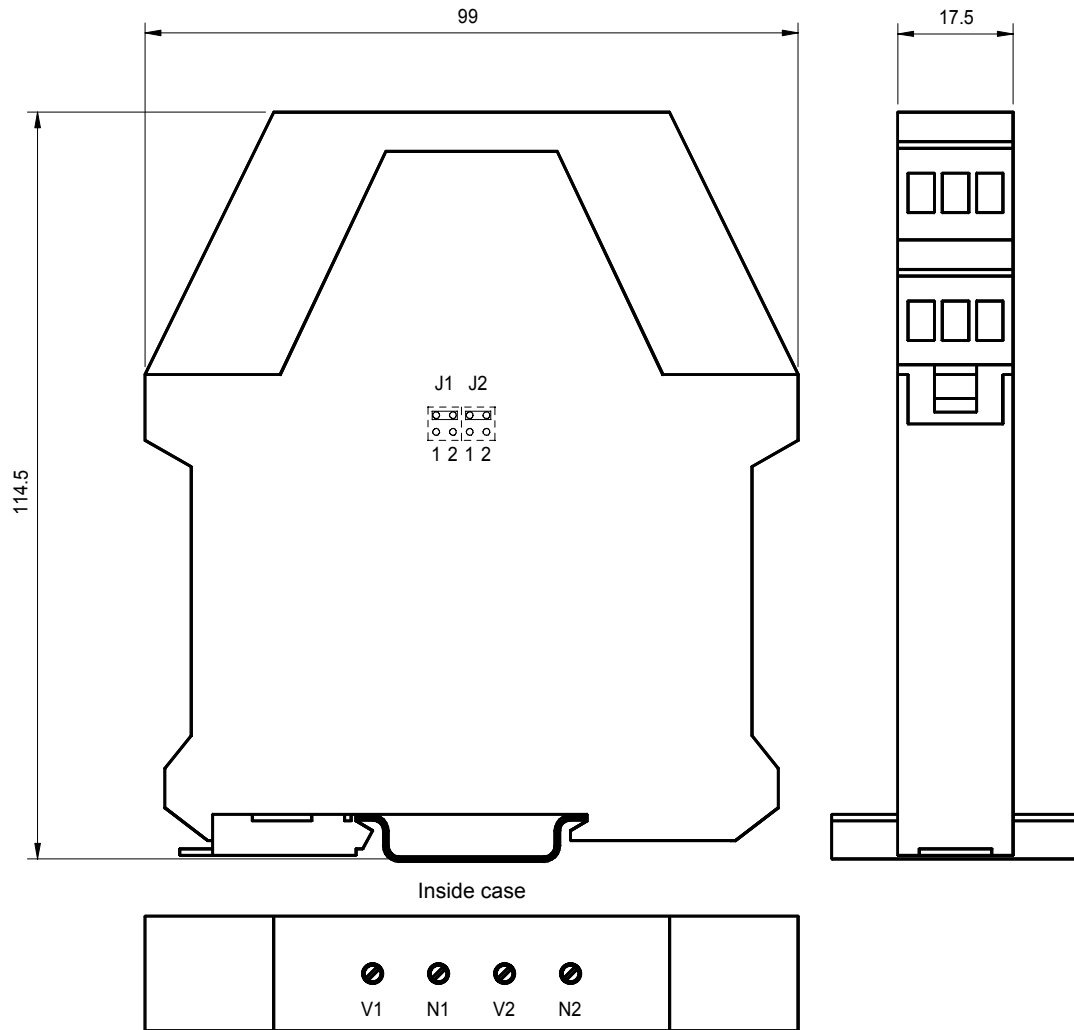

### Other versions:

- Equipped with Phoenix clamps
- Without trimmer
- Other supply voltage and output signals