

Inductive Displacement Transducer

preliminary
datasheet

Series **SM41 / SM43**



Programmable Inductive Transducer

The analogue signal of an inductive sensor is digitised in a 16bit A/D converter and processed in a micro-controller. The signal is linearised using the sensor's eeprom-stored variance of accuracy. Through a 16bit D/A converter the digital information is transformed back into a scaled analogue output signal of 0(4) – 20mA or 0 – 5(10)V. The measuring stroke can be individually programmed by the user.

Standard dimensions:

type	measuring stroke mm (factory preset)	mid L1 mm	housing length L2 mm	programmable measuring stroke	
				maximum mm	minimum mm ≤
SM41x.20	20	40	110	30	5
SM41x.40	40	50	140	50	8
SM41x.70	70	65	200	80	13
SM41x.100	100	80	250	110	18
SM41x.150	150	105	350	160	26
SM41x.200	200	120	500	210	34
SM43x.80	80	70	140	90	15
SM43x.170	170	115	250	180	29
SM43x.240	240	150	350	250	40
SM43x.360	360	210	500	370	60

Standard versions:

type	output	Supply voltage U_B (pole reversal protection)	signal ** (decreasing programmable)	mid
SM4x1	0 .. 20 mA *	10 .. 32 V	increasing	10 mA
SM4x3	4 .. 20 mA *	10 .. 32 V	increasing	12 mA
SM4x5	0..5 V	10 .. 32 V	increasing	2,5 V
SM4x7	0..10 V	15 .. 32 V	increasing	5 V

* Load $R_L \leq (U_B - 7 V) / 0,02 A$

** Increasing signal by moving the plunger in the direction towards the plug (factory preset)

Technical data:

Accuracy (at 20°C)	0,25% (optional 0,1%) (reference factory preset stroke)
Resolution	16 Bit
Dependence on U_B	$\Delta I_A / \Delta U_B < 0,02\% / V$ $\Delta U_A / \Delta U_B < 0,02\% / V$

For other data, dimensions and options, see datasheet SM40 / SM42

Electrical connections:

(view to the plug at the transducer)

5-pin plug Binder BI723	PUR-cable (option .KPx) 5 x 0,34 ² shielded (x = cable-length in meter)
1: + U_B (supply) 2: - U_B 3: I_A / U_A (output) 4: START 5: END	brown + U_B (supply) white - U_B green I_A / U_A (output) yellow START grey END

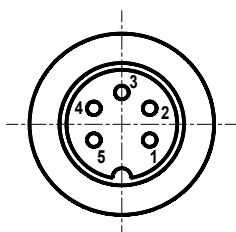

Programming an individual measuring stroke:

Notice:

Correct programming is only possible if the position of the plunger is within the maximum measuring stroke and the planned measuring stroke is not less than the specified minimum stroke (see table of "standard dimensions" on page 1).

With the sensor connected to the power supply and the output monitored, the sensor can be programmed by connecting START or/and END with $+U_B$ for a minimum of 2 seconds. Correct programming is indicated by a short jump (1 second) of the output signal to the mid-position signal.

Between every single programming step there has to be a minimum delay of 2 seconds (with START and END connected to $-U_B$ or open).

programming step	name	what to do	indicator output signal	error message
1	reprogramming the factory preset	connect START and (together) END to $+U_B$ (2 sec.)	mid-position (1 sec.) followed by correct measuring signal	Warning, if plunger is not within the maximum stroke: ¼-position signal (1 sec.) factory preset will be programmed
2	set start position	adjust plunger mechanically to the start position		
3	programming START position	connect START to $+U_B$ (2 sec.)	mid-position (1 sec.) followed by start output signal	If plunger is not within the maximum stroke: ¼- position signal (1 sec.) START position is set to the nearest limit of the maximum measuring stroke
4	set end position	adjust plunger mechanically to the end position		
5	programming END position	connect END to $+U_B$ (2 sec.)	mid-position (1 sec.) followed by end output signal	Less than the minimum measuring stroke: ¾ - position signal (1 sec.) No programming !
				If plunger is not within the maximum stroke: ¼-position signal (1 sec.) END position is set to the nearest limit of the maximum measuring stroke

During normal measurement operation, we recommend to connect START and END to $-U_B$.

For example SM431.80 :

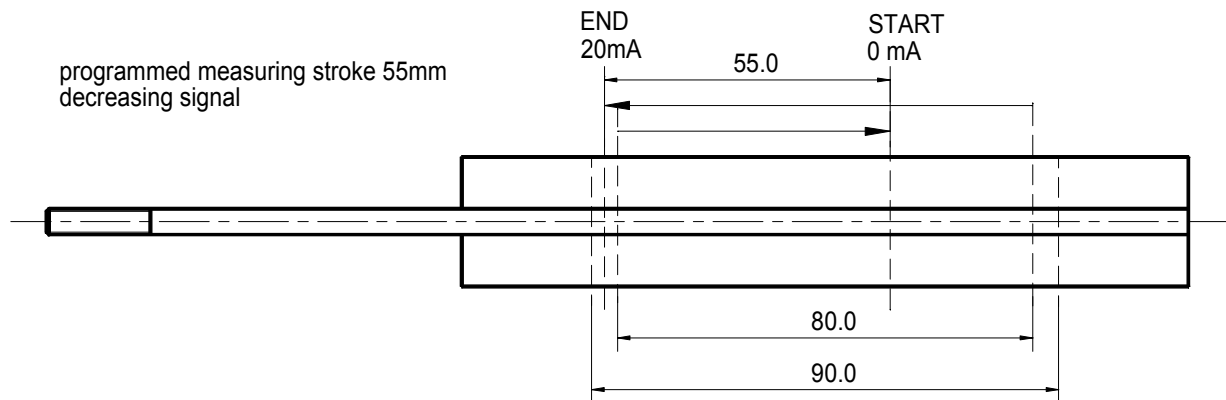
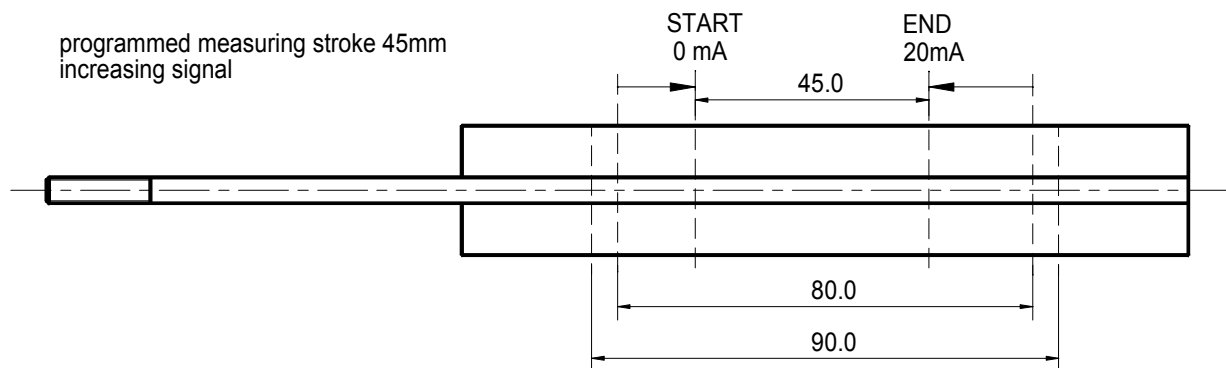
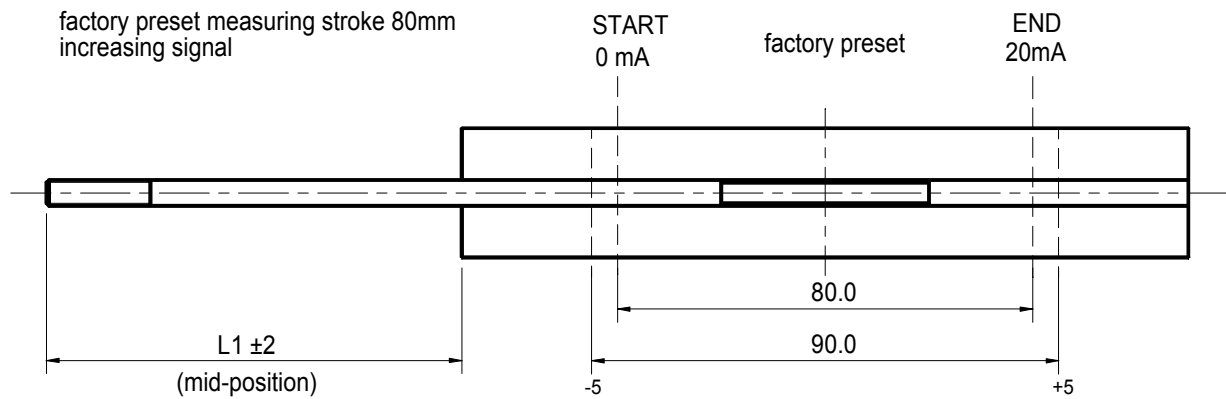

Order code

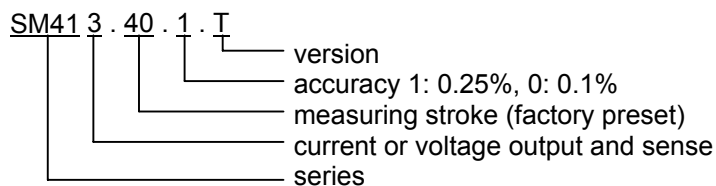

Order codes for customer specified versions will be named at plant.

For example: SM413.40.1.T

Gauge series 41, output 4-20 mA , 40mm measuring stroke (factory preset), accuracy 0.25%

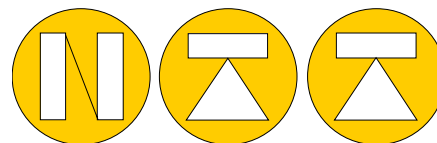

- Universally usable displacement sensor
- Stroke from 20 up to 200mm or 80 up to 360mm
- Integrated electronic circuit with programmable working range.
- Protection IP66
- Accuracy 0.1% or 0.25%



Standard measuring strokes:

20mm	40mm	70mm	100mm	150mm	200mm
80mm	170mm	240mm	360mm		

Technical data:

Accuracy	< 0.25% or 0.10%
Temperature drift	< 0,01 % / °C
Frequency limit	800 Hz
Temperature range	-20°C up to +85°C
Resistance to shock	250g SRS 20-2000Hz
Resistance to vibration	20g rms (50g peak)
Protection class	IP66*

* Mount mating plug Binder series 423 (IP67)
 Binder serie 680 are used as standard supply (IP40)

Current output (SM411..413 / SM431..433):

Output signal	0..20 mA or 4..20 mA
Supply current I _B	max. 60 mA
Load resistance R _L	0..500 ohm
Residual ripple	< 0.005 mA _{SS}
Dependence on R _L	< 0.001% at RL=100ohm
Dependence on U _B	< 0.05% at UB = 1V

Voltage output (SM415..417 / SM435..437):

Output signal	0..5 VDC or 0..10 VDC
Supply current I _B	max. 50 mA
Permissible load R _L	>2kohm(shortcircuit proof)
Residual ripple	< 5 mV _{SS}
Residual voltage SM417/437	max. 0,1VDC
Dependence on U _B	< 0.05% at „UB = 1V

Operating principle:

A nickel iron core will be moved linear inside a coil. The displacement of the core leads to an inductance variation in parts of the coil. That generates more information about the position of the core than a linear variable differential transformer or a half-bridge transformer. The integrated electronic circuit converts this information's into a signal proportional to the displacement of the core.

Materials:

External and internal tube	Stainless steel
Plunger	Stainless steel
Core	Stainless nickel-iron core
Connector housing	Nickel plated brass
Connector contacts	Gold plated brass

Note: Unless otherwise stated, all values are valid at +20°C ambient temperature and 24V DC supply voltage, starting 10 minutes after switch-on.

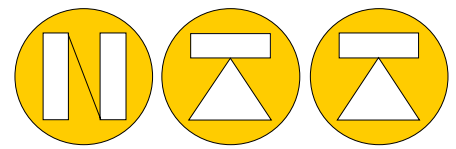

NORDIC TRANSDUCER

Inductive displacement transducer Series SM41 / SM43

Dimensions and masses SM41x.F:

Stroke mm	L1 mm	L2 mm	Transducer	Plunger
20	40	110	210g	15g
40	50	140	240g	19g
70	65	200	310g	25g
100	80	250	380g	31g
150	105	350	520g	41g
200	130	500	720g	56g

L1 = Plunger in central position

Dimensions and masses SM43x.F:

Stroke mm	L1 mm	L2 mm	Transducer	Plunger
80	70	140	240g	19g
170	115	250	380g	31g
240	150	350	520g	41g
360	210	500	720g	56g

L1 = Plunger in central position

SM41x.F SM43x.F

F = POM guide for plunger

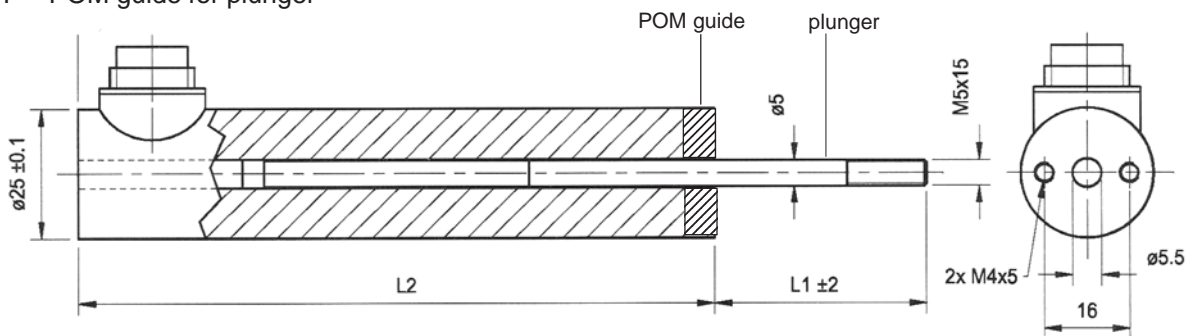

SM41x.Kxx SM43x.Kxx

K = cable with PG9 and shielded cable 4 x 0,56 mm²

KPy = cable with PG9 and PUR oil resistant shielded cable 3 x 0,56 mm²

xx = cable length

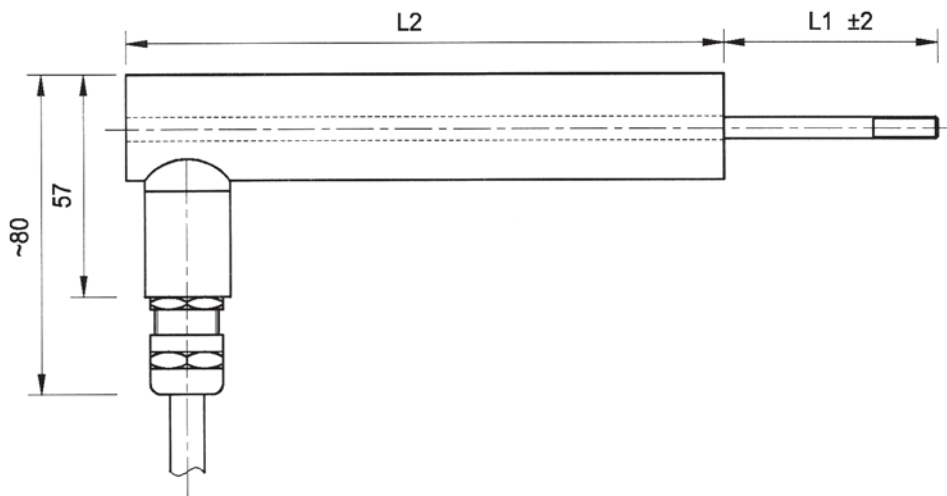

Inductive displacement transducer Series SM41 / SM43

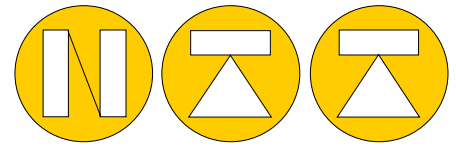

NORDIC TRANSDUCER

Dimensions and masses SM41x.FGH:

Stroke mm	L1 mm	L2 mm	Transducer	Plunger
20	40	110	210g	15g
40	50	140	240g	19g
70	65	200	310g	25g
100	80	250	380g	31g
150	105	350	520g	41g
200	130	500	720g	56g

L1 = Plunger in central position

Dimensions and masses SM43x.FGH:

Stroke mm	L1 mm	L2 mm	Transducer	Plunger
80	70	140	240g	19g
170	115	250	380g	31g
240	150	350	520g	41g
360	210	500	720g	56g

L1 = Plunger in central position

SM41x.FGH SM43x.FGH

F = POM guide for plunger

G = Ball bearing on plunger

H = Mount + ball bearing at housing

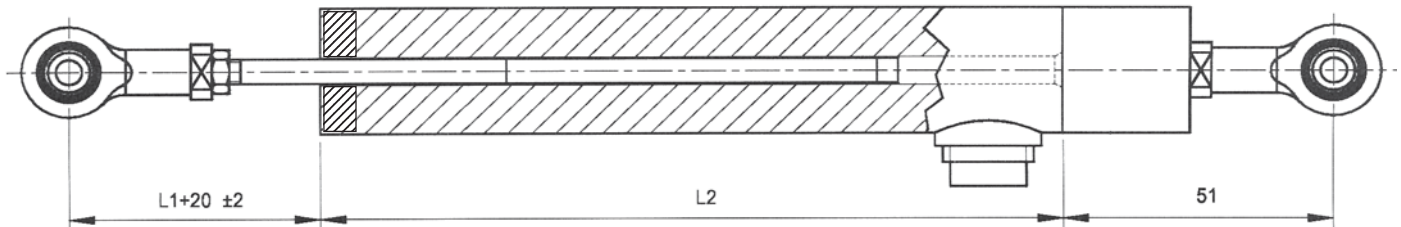

SM41x.T

T = Return spring up to 100mm

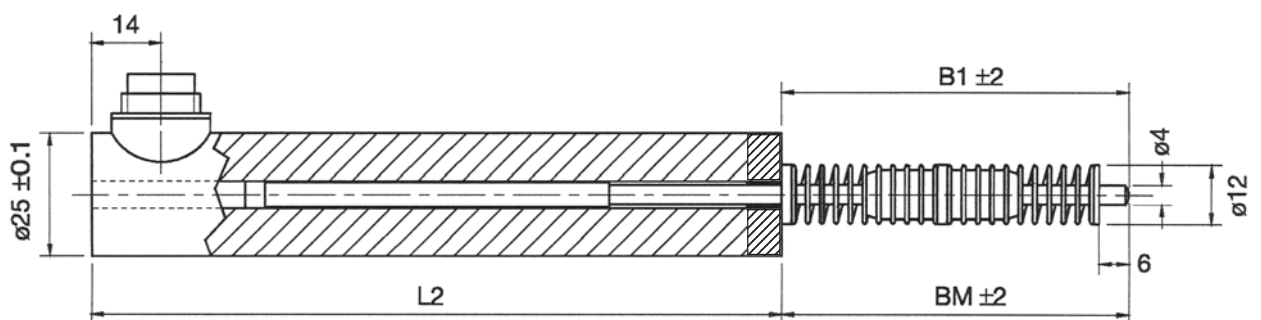

Dimensions and spring force SM41x.T:

Stroke mm	BM mm	B1 mm	L2 mm	Fm N	Fc N/mm
20	70	85	110	~4	0.07
40	70	98	140	~4	0.07
70	110	160	200	~4	0.05
100	140	195	250	~4	0.03

BM = Plunger in central position, B1 = plunger fully extended,
Fm = spring force in central position, Fc = spring rate

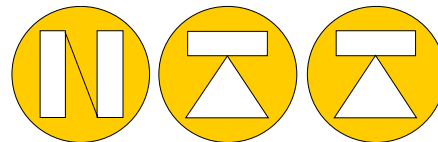

NORDIC TRANSDUCER

SM41x / SM43x Versions / options

- F = POM guide for plunger
- G = Ball bearing on plunger M5
- H = Mount and ball bearing at housing M5
- T = Gauge type Spring up to 100mm
- K = Cable outlet
- KP = Cable PUR type
- .0 = 0.10% linearity (41/30.xx.0)
- .1 = 0.25% linearity (41/30.xx.1)
- SM901.401 = Binder serie 423 connector
- SM906.400 = Clamp (brass nickel plated)
- SM906.401 = Clamp (Polypropylene)

Assembly clamps

SM906.400

Brass, nickel-plated

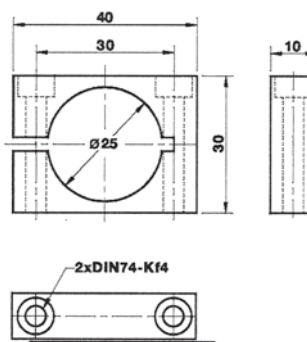

(incl.2 fastening screws
M4x35 DIN912 VA)

SM906.401

Polypropylene

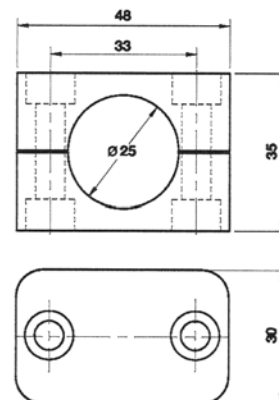

(incl.2 fastening screws
M6x35 DIN912 VA)

ORDER CODE

SM41 3 .70 .1 .F

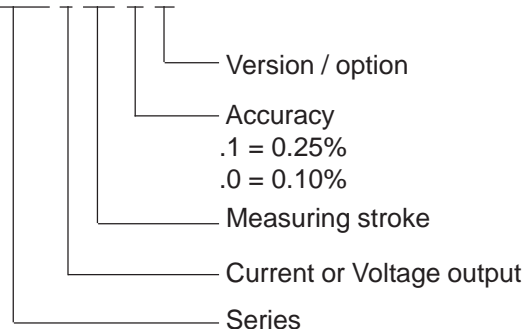

Example: **SM413.200.1.FG**

Serie 413, output 4-20mA (increasing)
200mm stroke, accuracy 0.25%, FG guide + Ball bearing plunger
+ 2 x SM906.401 clamps



Inductive displacement transducer Series SM41 /43

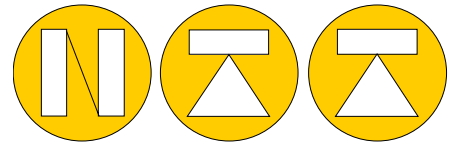

NORDIC TRANSDUCER

Serie 410 shown with SM906.401 Clamp



SM413.20.1.FGH

Standard Binder Series 680 5 pole connector



SERIES 410 for strokes from 0-20mm to 0-200mm

SM433.170.1.FG

SM906.400 brass mounting blocks

G Option = Stainles Steel ball bearing

F option = POM guide

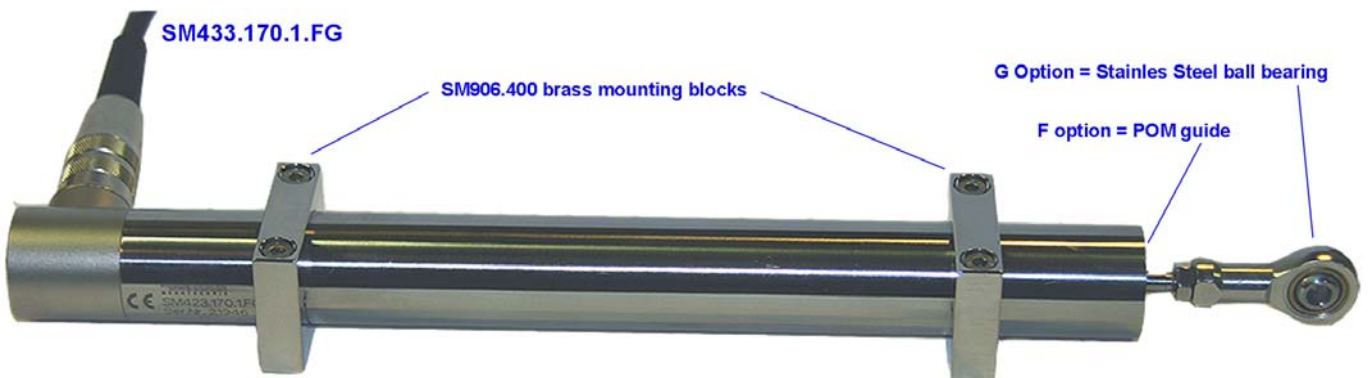

SERIES 430 for strokes from 0-80mm to 0-360mm