

# GR5A Digital Dynamometer

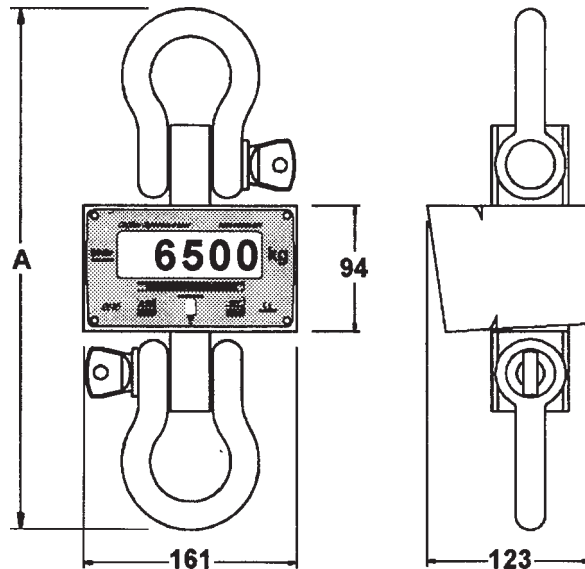
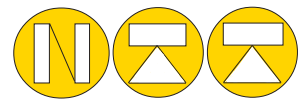

GR5/500kg-3t    A = 270mm  
 GR5/6.5t        A = 400mm  
 GR5/9.5t        A = 477mm

The **GR5A** series digital dynamometer consist of a stainless steel strain gauge load cell ensuring a high long-term accuracy and reliability, and of an advanced microprocessor indicator.

The indicator has a 25mm high 5 digit LCD display, showing the measured weight; overload and low battery are detected by an acoustic warning.

The use of a chain of carrier frequency based amplifiers-converters allows thermal drift to be reduced to a minimum. The 4 easy to find internal batteries and the AUTOPOWER OFF function ( automatic switching off after 30 minutes ), ensure a 1 year of autonomy without recharge. Its versatility and light weight make it easy to install in factories, warehouse, shipping centres etc.

**The GR5 is equipped with 2 enclosed spherical joints for the load self-alignments: this improves the measurement accuracy and makes other components ( rings ) needless, with their vertical dimensions**

## GR5A SPECIFICATIONS

NOMINAL LOAD	500kg x 0.1kg    1t x 0.2kg    3t x 0.5kg    6.5t x 1kg    9.5t x 2kg		
		READINGS PER SEC.	1
WORKING RANGE	from 0-100%	SERVICE TEMP. RANGE	-10/+50 °C
COMBINED ERROR	< +/- 0.05%	Zero Remote Control	Max. 4m
MAX. PERMISSIBLE LOAD	150 % F.S.	WEIGHT	3.5 - 7.5 - 12 kg
BREAKING LOAD	> 500% F.S	CELL MATERIAL	Stainless steel
PROTECTION CLASS	IP40	ALKALINE BATTERIES	1.5V size AA

**GR5** is delivered complete with: Travelling case, Galvanized Shackles  
 Remote Zero Control, 4 x 1.5V Alkaline batteries

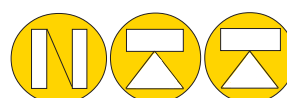

## Nordic Transducer

Als Odde, DK-9560 Hadsund Denmark  
 Tel.: +45 98581444, Fax.: +45 98581866  
 E-mail: [ntt@ntt.dk](mailto:ntt@ntt.dk) WEB: [www.ntt.dk](http://www.ntt.dk)